



Extend oil use



Reduce maintenance



Reduce breakdowns



Detect contamination

PRODUCT DESCRIPTION

The Oil Quality Telemetry Gateway (OQTg) is a sophisticated industrial IoT Gateway device that enables data from your OQSx-G2 sensors to be accessed using any online M2M/IoT monitoring system, such as Tan Delta Online.

The Gateway enables data transmission using a variety of methods depending upon location and network availability. These include Cellular, WiFi and Ethernet.

Every equipment operator knows that machine monitoring enables effective management and thus increased reliability, efficiencies and profits. Oil condition monitoring with Tan Delta takes this to a new level through much greater insight into the real condition of your equipment to deliver significantly enhanced financial and operating benefits.

KEY FEATURES

- **System integration**
Supports up to 16 sensors simultaneously, and the cables can be varying lengths to ensure easy installation, integration and operation.
- **Connectivity to TD-online**
A data hub and dashboard view of monitored assets and alerts you to developing issues prior to any equipment damage or lost production. The interface is similar across desktop/tablet/smart phone views for ease of use.
- **Simple to deploy**
Allowing quick and simple installation on any piece of equipment, whether brand new or being installed as part of a retrofit.
- **Industrial quality**
IP67 rated, suitable for installation in any harsh commercial or industrial environment.
- **Independently tested**
The Gateway has undergone rigorous independent testing to verify its outstanding performance in a wide variety of applications.

BENEFITS

- **Monitor all site assets**
Connect up to 16 OQSx-G2 sensors using the Gateway and modular cabling system, enabling you to view the health status and location of your entire fleet of assets at the click of a button.
- **Reduce breakdowns and damage**
Improve efficiency and extend the life of your equipment by ensuring optimal oil condition and reliable early detection of potential issues before wear particles are present and damage occurs.
- **Extend oil drain intervals**
Safely extend oil life and drain intervals by monitoring real-time degradation and conduct maintenance when there is actual need, rather than on an 'hours run' basis.

TECHNICAL DATA

Product information

Name	Oil Quality Telemetry Gateway
Product No.	Gateway

Physical

Enclosure	Glass reinforced plastic
Dimensions	149mm x 135mm x 58mm (L x H x W)
Weight	400g

Connections

Antenna connector	FAKRA antenna
System connector	TE 776163-1 (35 pins)
Other	MicroSD card slot Micro SIM slot USB host 2.0 Wifi 2.4GHz Ethernet 10/100 BaseT

GSM/GPRS

GSM	GSM850 + EGSM900 + GSM1800 + GSM1900 Class 4 (2W) GSM850/EGSM900 Class 1 (1W) GSM1800/GSM1900
GPRS	GPRS Class B, Class 10 (4+2) Audio and CSD Data calls SMS (MT/MO) Optional HSPA+ (3G) and LTE (4G) support

GNSS positioning

Receiver	GPS L1 frequency. C/A code *56 channels* continuous tracker receiver. GALILEO L1 open service and GLONASS ready*
SBAS	WAAS, EGNOS, MSAS, GAGAN

Accuracy	2.5 meters CEP
Signal acquisition	Cold start: 29 sec* Warm Start: 28 sec* Hot start < 1 sec Reacquisition < 1 sec Active Antenna

Power

Supply	9V to 48V
Batteries	Standard backup battery for RTC. Duration 10 years. Optional rechargeable battery Li-Ion 3.7V at least 2600mAh. Inserted via rear battery cover.

System specs and CPU

ARM cortex A8	800MHz clock speed
LINUX OS	Kernel 4.4
RAM	512MByte DDR3
NAND flash	1 GByte
Additional storage	32GB+ with MicroSD card

Environmental

Storage temperature	-40°C to +85°C (-40°F to + 185°F)
Operating GSM off	-40°C to +85°C (-40°F to + 185°F)
Operating GSM on	-30°C to + 80°C (-22°F to + 176°F)
Li-ion battery	-20°C to + 60°C (-4°F to +140°F) (recharge 0°C to + 45°C, 113°F)

Standards and certification

Conformity	CE marked E - Automotive Zulassung entsprechend Kfz-EMV-Richtlinie R & TTE RoHS compliant
------------	--

DIMENSIONS AND CONNECTIONS

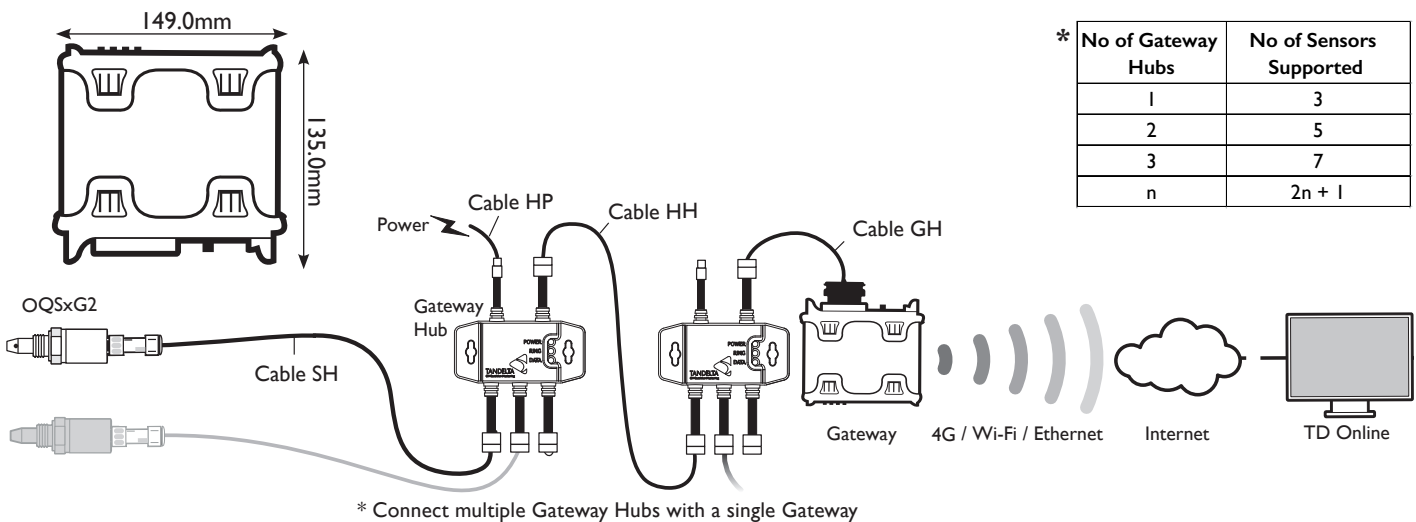

WHY TAN DELTA

Tan Delta advanced oil condition analysis technologies and products enable enhanced and highly accurate real-time monitoring and management of oil and rotating equipment. Superior accuracy combines with fully holistic analysis to deliver the ultimate equipment monitoring capability and insight. Used and trusted around the world by equipment operators to reduce costs and improve efficiency. Tan Delta provide ready-to-go equipment to end users, as well as embedded and customised product solutions to original equipment manufacturers.

OEM Tan Delta provide OEM equipment manufacturers with fully customised integrated and cost-optimised solutions. Please contact us directly to discuss your oil condition requirements.